

MODEL 86 Ultrastable

316L SS Pressure Sensor

High Performance, Small Profile

0-100 mV Output

Absolute and Gage

Low Pressure



DESCRIPTION

The Model 86 is a small profile, media compatible, piezoresistive silicon pressure sensor packaged in a 316L stainless steel housing. The Model 86 is designed for O-ring mounting. The sensing package utilizes silicon oil to transfer pressure from the 316L stainless steel diaphragm to the sensing element.

The Model 86 is designed for high performance, low pressure applications. A ceramic substrate is attached to the package that contains laser-trimmed resistors for temperature compensation

and offset correction. An additional

lasertrimmed resistor is included which can be used to adjust an external differential amplifier and provide span interchangeability to within $\pm 1\%$.

Sensors with threaded pressure fittings, weldable flush sensors and high pressure stainless steel sensors are also available. Please contact the factory for more information.

FEATURES

- ◆ O-Ring Flush Mount
- ◆ -20°C To +85°C Compensated Temperature Range
- ◆ $\pm 0.1\%$ Pressure Non-linearity
- ◆ $\pm 1.0\%$ Interchangeable Span (provided by gain set resistor)
- ◆ Solid State Reliability
- ◆ Low Power

APPLICATIONS

- ◆ Hydraulic Controls
- ◆ Process Control
- ◆ Oceanography
- ◆ Refrigeration/Compressors
- ◆ Pressure Transmitters
- ◆ Level Systems

dimensions

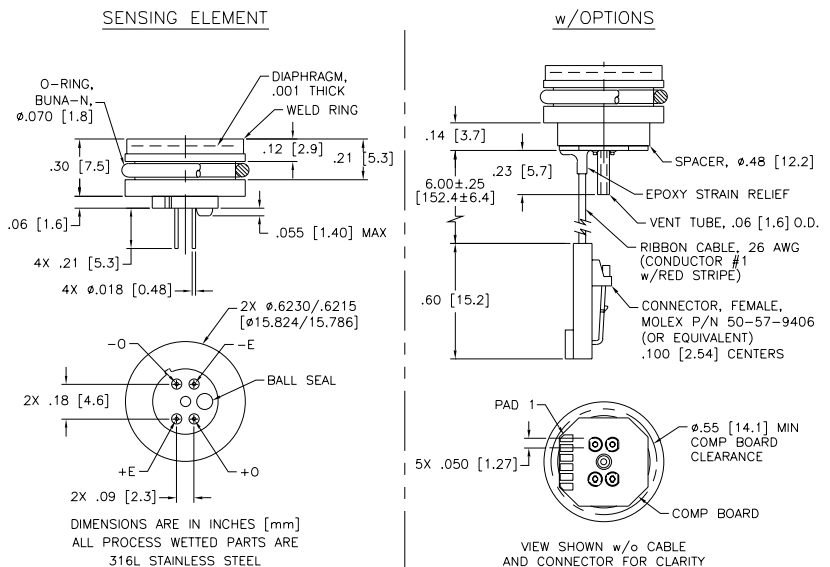

MODEL 86 Ultrastable

performance specifications

All parameters measured at 1.5mA drive and at 25°C after 10 second warm up, unless otherwise specified. Unless specifically indicated, only those parameters indicated as tested are verified on each part. Parameters are specified for the compensated version only.

PARAMETERS	MIN	TYP	MAX	UNITS	NOTES
Full Scale Output Span	75	100	150	mV	1
Zero Pressure Output (Offset)	-1	0	1	mV	2
Pressure Non-linearity	-0.10		0.10	±% Span	3
Pressure Hysteresis	-0.5	0.02	+0.05	±% Span	
Repeatability		0.02		±% Span	
Input Resistance	2000	3500	4500	Ω	
Output Resistance	4000		25000	Ω	
Temperature Error - Span (-20 to 85°C)	-0.75		+0.75	% Span	4
Temperature Error - Offset (-20 to 85°C)	-0.5		+0.5	% Span	4, 5
Thermal Hysteresis - Span		0.05		% Span	4
Thermal Hysteresis - Offset		0.05		% Span	4
Long Term Stability of Span		0.1		±% Span/yr.	
Long Term Stability of Offset		0.1		±% Span/yr.	
Supply Current	0.5	1.5	2.0	mA	6
Output Load Resistance	5			MΩ	7
Insulation Resistance (50 VDC)	50			MΩ	8
Pressure Overload			3X	Rated	
Compensated Temperature Range	-20°C to +85°C	9			
Operating Temperature Range	-40°C to +125°C	9			
Storage Temperature Range	-50°C to +125°C	9			
Media - Pressure Port	Liquids and Gases compatible with 316L Stainless Steel				
Media - Reference Port	Compatible with Silicon, Pyrex, Gold, Fluorosilicon Rubber and 316L Stainless Steel				
Weight	13 grams				

Notes

- For amplified output circuits see application note TN-003.
- Measured at vacuum for absolute (A), ambient for gage (G).
- Best fit straight line.
- Over the temperature range -20°C to +85°C with respect to +25°C.
- 15 psi range sensors have an offset temperature error of ±0.75% (Max) from -20°C to +85°C.
- Guarantees output/input ratiometricity.
- Load resistance to reduce measurement errors due to output loading.
- Between case and sensing element.
- Maximum temperature range for product with standard cable and connector is -20°C to +105°C.
- For gage units used at pressures below atmosphere, the span accuracy is not guaranteed.
- Standard gauge units are not recommended for vacuum applications. For vacuum applications below 1/2 atmosphere, contact factory.

standard ranges

Range	psig	psia
0 to 15	•	•
0 to 30	•	•
0 to 50	•	•
0 to 100	•	•
0 to 300	•	•
0 to 500	•	•

ordering information

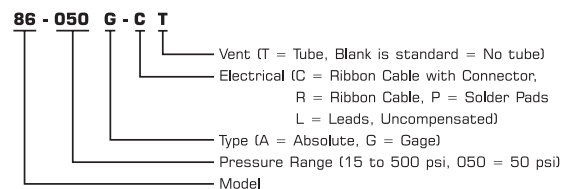

For other ranges, process fittings and electrical connections contact factory.

connections

Pad/Cable No.	Function
1	+OUT
2	-EX
3	+EX
4	-OUT
5	GAIN
6	GAIN

application schematic

